



TWIN F II 3.0 A/U

Double Scissors Lift

Parts Breakdown

ET082501-en



Lifting Technology



DIN EN ISO 9001:2008
ISO 14001:2004

SINCE 1969

Premium Workshop
Equipment

© MAHA Maschinenbau Haldenwang GmbH & Co. KG

Legal notice based on ISO 16016:

The reproduction, distribution and utilization of this document as well as the communication of its contents to others without explicit authorizations is prohibited. Offenders will be held liable for the payment of damages. All rights reserved in the event of the grant of a patent, utility model or design.

The contents of this edition have been checked with great care. However. Errors cannot be fully excluded. Subject to technical change without notice.

Document

Document N^o: ET082501-en
Approval Date: 19.04.2012

Manufacturer

MAHA Maschinenbau Haldenwang GmbH & Co. KG
Hoyen 20
87490 Haldenwang
Germany

Phone: +49 (0) 8374 585 0
Fax: +49 (0) 8374 585 590
Fax Parts: +49 (0) 8374 585 565
Internet: <http://www.maha.de>
E-Mail: maha@maha.de
Hotline: +49 (0) 180 56242 60 for Brake Testers and Test Lanes
+49 (0) 180 56242 80 for Automotive Lifts
+49 (0) 180 56242 90 for Dynamometers and Emission Testers

Service

AutomoTec GmbH
Maybachstraße 8
87437 Kempten
Germany
Phone: +49 (0) 180 56242 50
Fax: +49 (0) 180 56242 55
Internet: <http://www.automo-tec.com>
E-Mail: service@automo-tec.com

Contents

TWIN F II 3.0 A/U

- 1 Floor Group 4
 - 1.1 Scissors 6
 - 1.2 Runways 8
 - 1.3 Ramps, Drive-Over Ramps and Insert Parts 9
 - 1.4 Power Unit Cabinet 10
 - 1.5 Hydraulic Power Unit 12
- 2 Small Parts 13
- 3 Labels 16
- 4 Electrical Equipment 17
- 5 Anchors 21

1 Floor Group

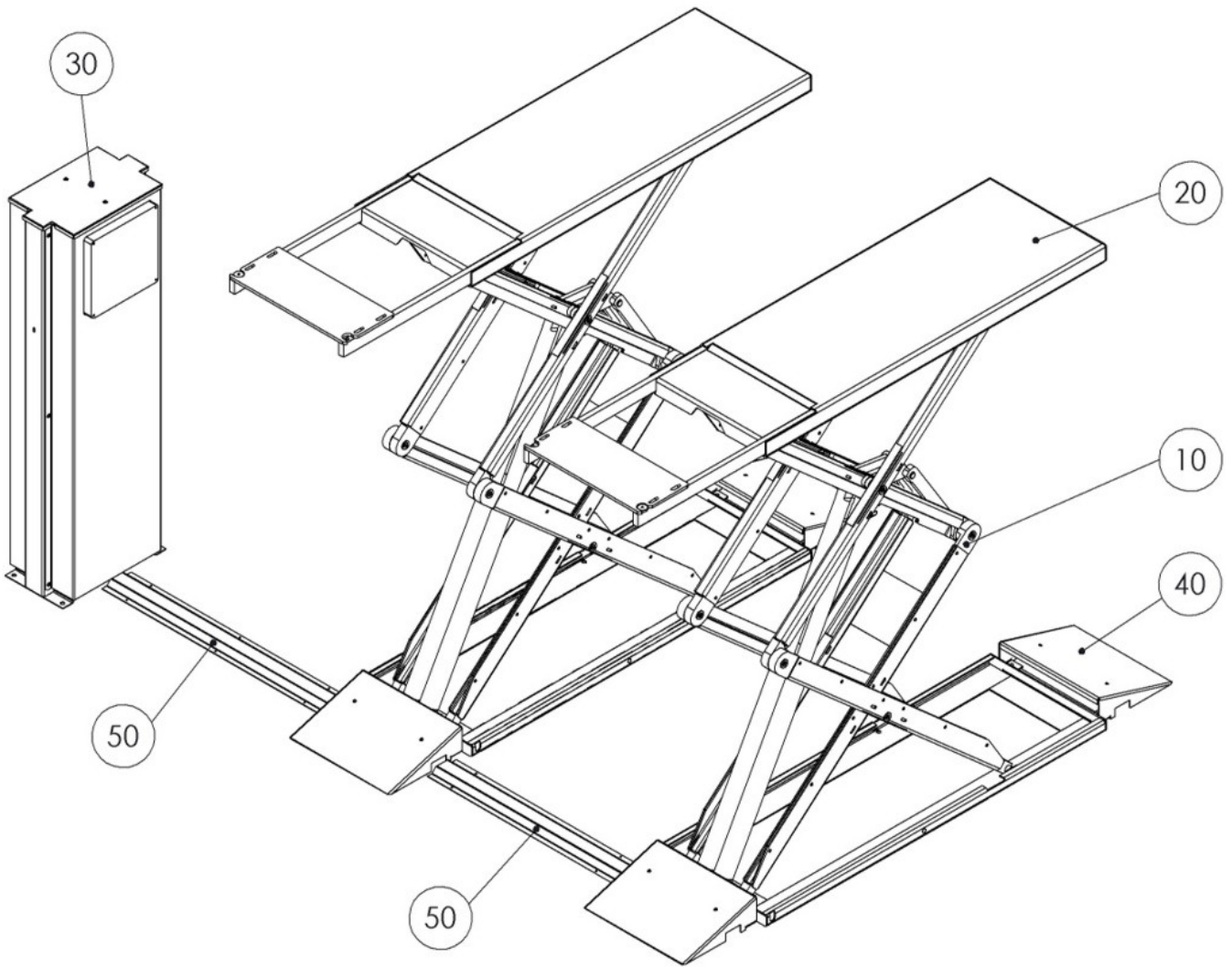

Item No.	Spare Part	Description	Tooltip	Article Number
10	Scissors		Section 1.1	
20	Runways		Section 1.2	
30	Power Unit Cabinet		Section 1.4	030081 00024 0
40	Ramps		Section 1.3	
50	Cover	850mm		020081 00095 0
	Cover	1000mm		020081 00096 0
	Cover	90°, 400mm, Right		020081 01032 0
	Cover	90°, 400mm, Left		020081 01033 0

1.1 Scissors

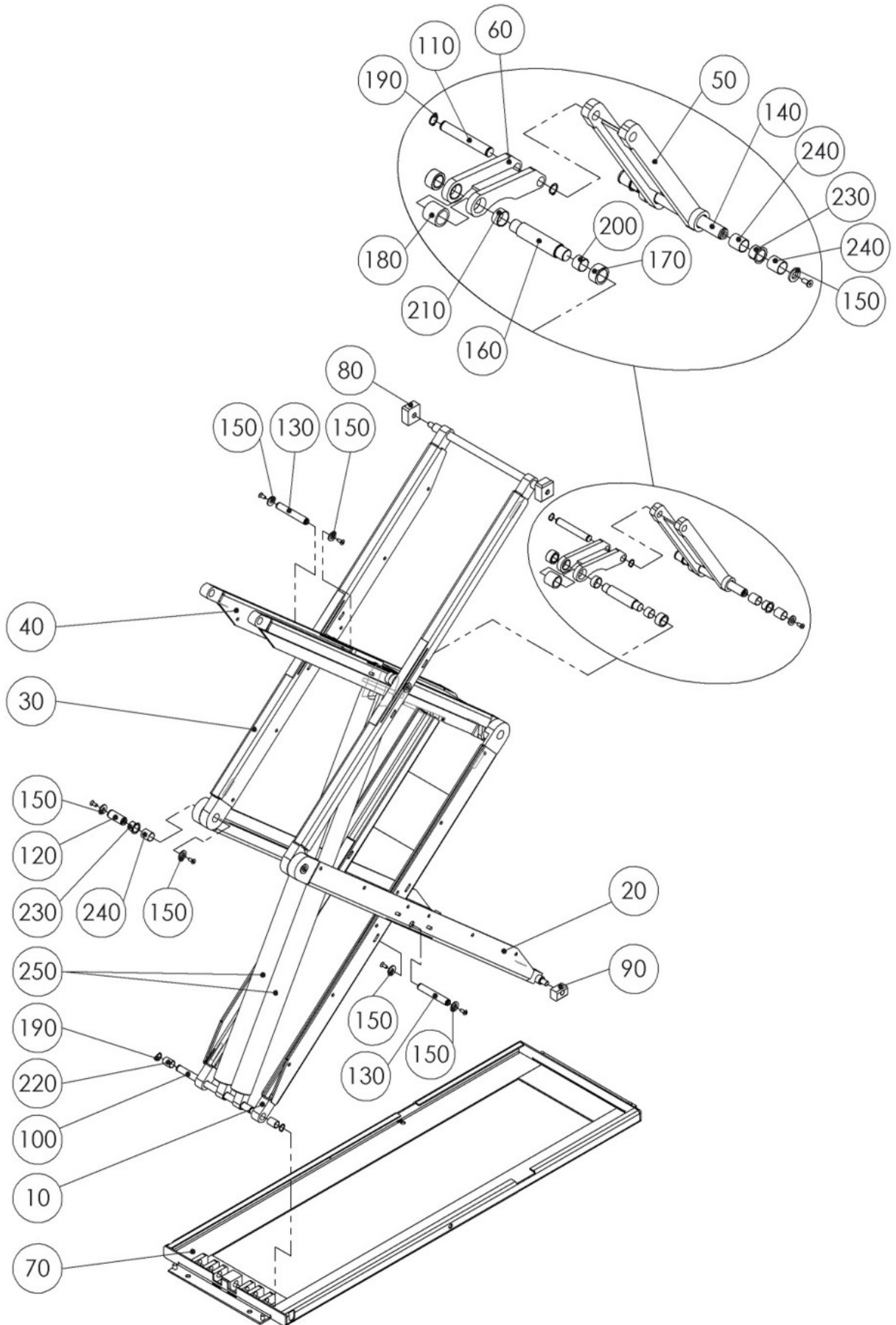

Item No.	Spare Part	Description	Article Number
10	Inner Scissors	Bottom	030081 00006 0
20	Outer Scissors	Bottom	030081 00009 0
30	Outer Scissors	Top	030081 00012 0
40	Inner Scissors	Top	030081 00050 0
50	Raising Lever	Bottom	030081 00020 0
60	Raising Lever	Top	030081 00053 0
70	Floor Plate	Powder Coated	030081 00003 0
	Floor Plate	Hot-dip Galvanized	030081 00047 0
80	Slider Block	Top	020081 00040 0
90	Slider Block	Bottom	020081 00042 0
100	Pin		020081 00047 0
110	Pin	Raising Lever	020081 00048 0
120	Pin	Short	020081 00090 0
130	Pin	Long	020081 00091 0
140	Spacer Pin		020081 00092 0
150	Washer		020081 00093 0
160	Axle		020081 01035 0
170	Roller		020081 01037 0
180	Spacer Sleeve		020081 01041 0
190	Snap Ring	20x1,2	22 0471 020
200	Friction Bearing		24 1725
210	Friction Bearing		24 1730 2
220	Friction Bearing		24000004
230	Friction Bearing		24000005
240	Friction Bearing		24000006
250	Hydraulic Cylinder		26000160

1.2 Runways

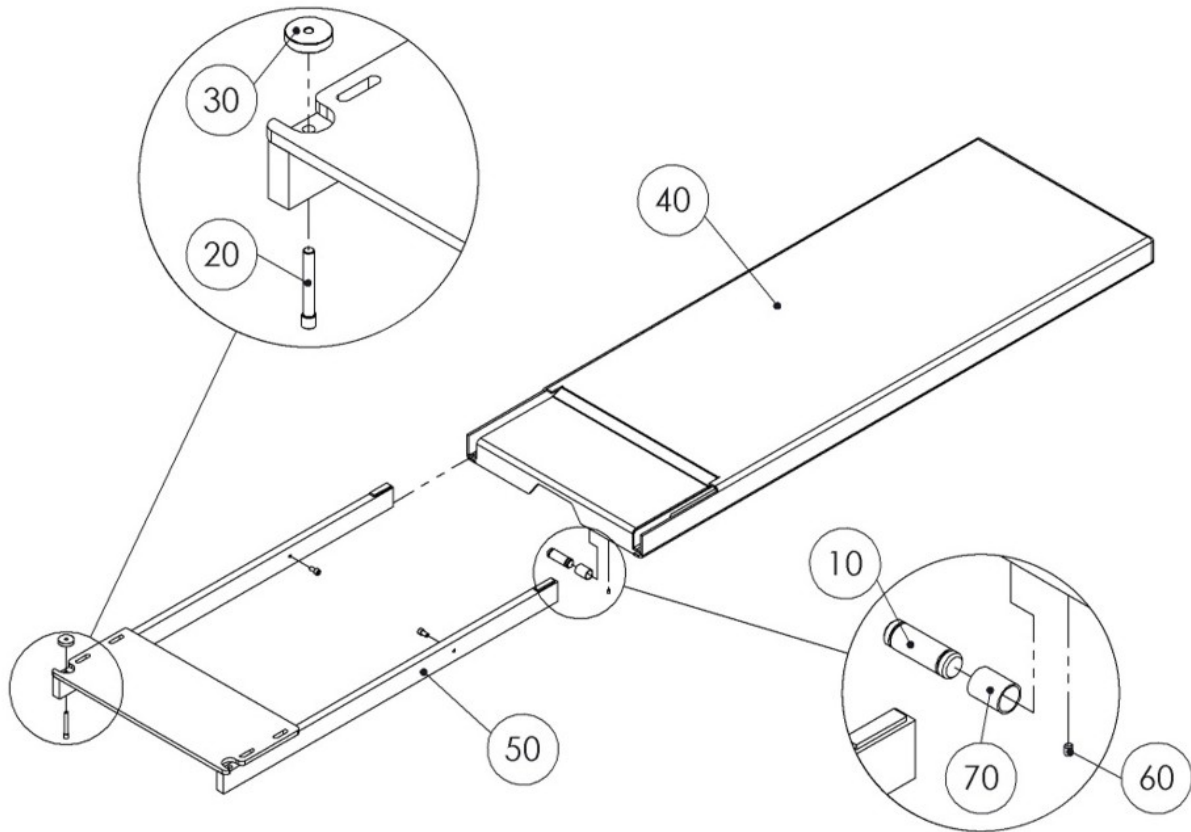

Item No.	Spare Part	Article Number
10	Pin	020081 00041 0
20	Pin	020081 00051 0
30	Washer	020081 00052 0
40	Runway	030081 00045 0
50	Extension	030081 00046 0
60	Threaded Pin	22 0913 06008 3
70	Friction Bearing	24000004

1.3 Ramps, Drive-Over Ramps and Insert Parts

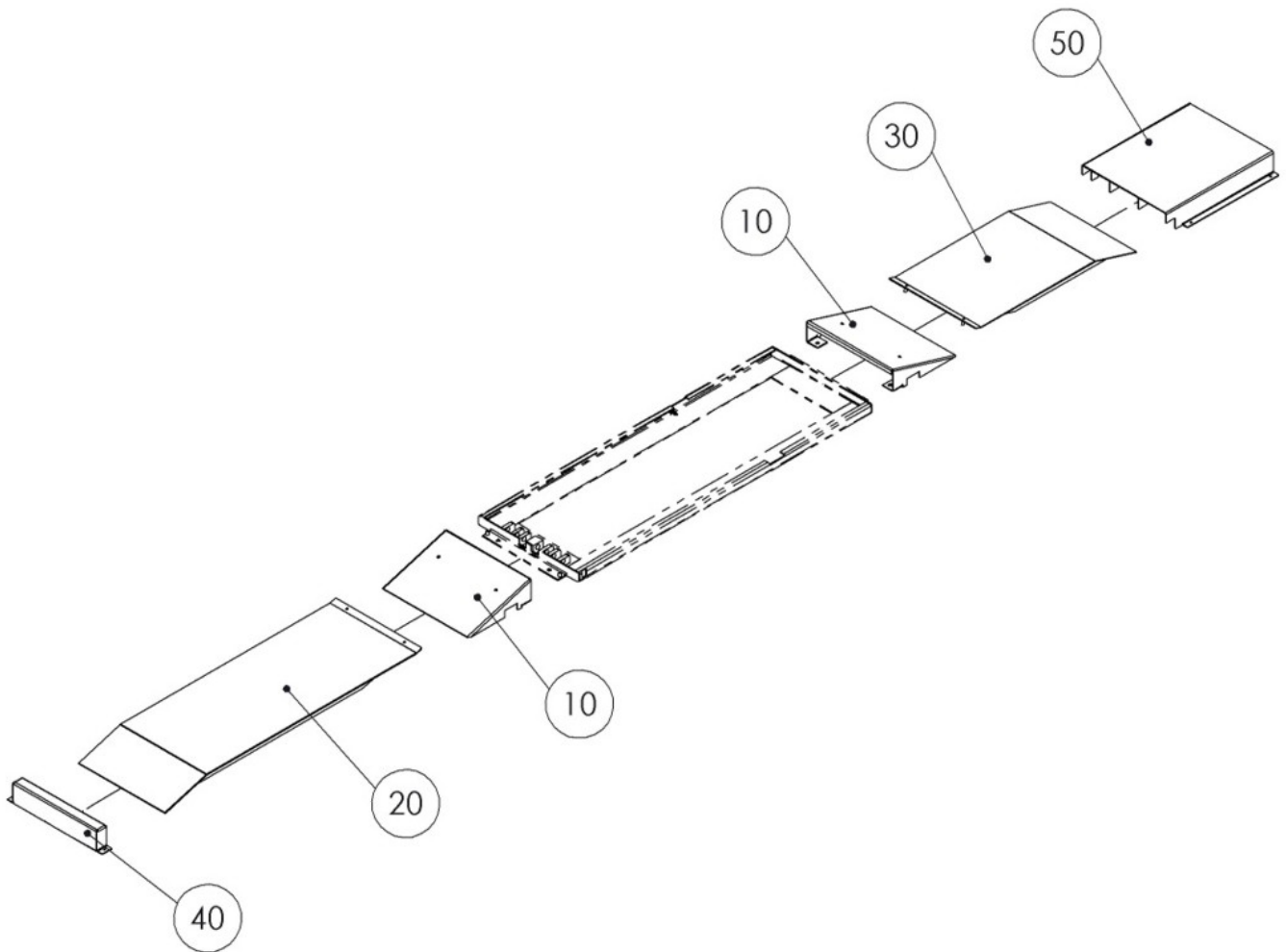

Item No.	Spare Part	Description	Article Number
10	Ramp	Powder Coated	020081 00089 0
	Ramp	Hot-dip Galvanized	020081 01024 0
20	Drive-Over Ramp	Long	030081 00041 0
30	Drive-Over Ramp	Short	030081 00042 0
40	Insert Part, Short	Powder Coated	020081 00069 0
	Insert Part, Short	Hot-dip Galvanized	020081 01047 0
50	Insert Part, Long	Powder Coated	030081 00026 0
	Insert Part, Long	Hot-dip Galvanized	030081 00049 0

1.4 Power Unit Cabinet

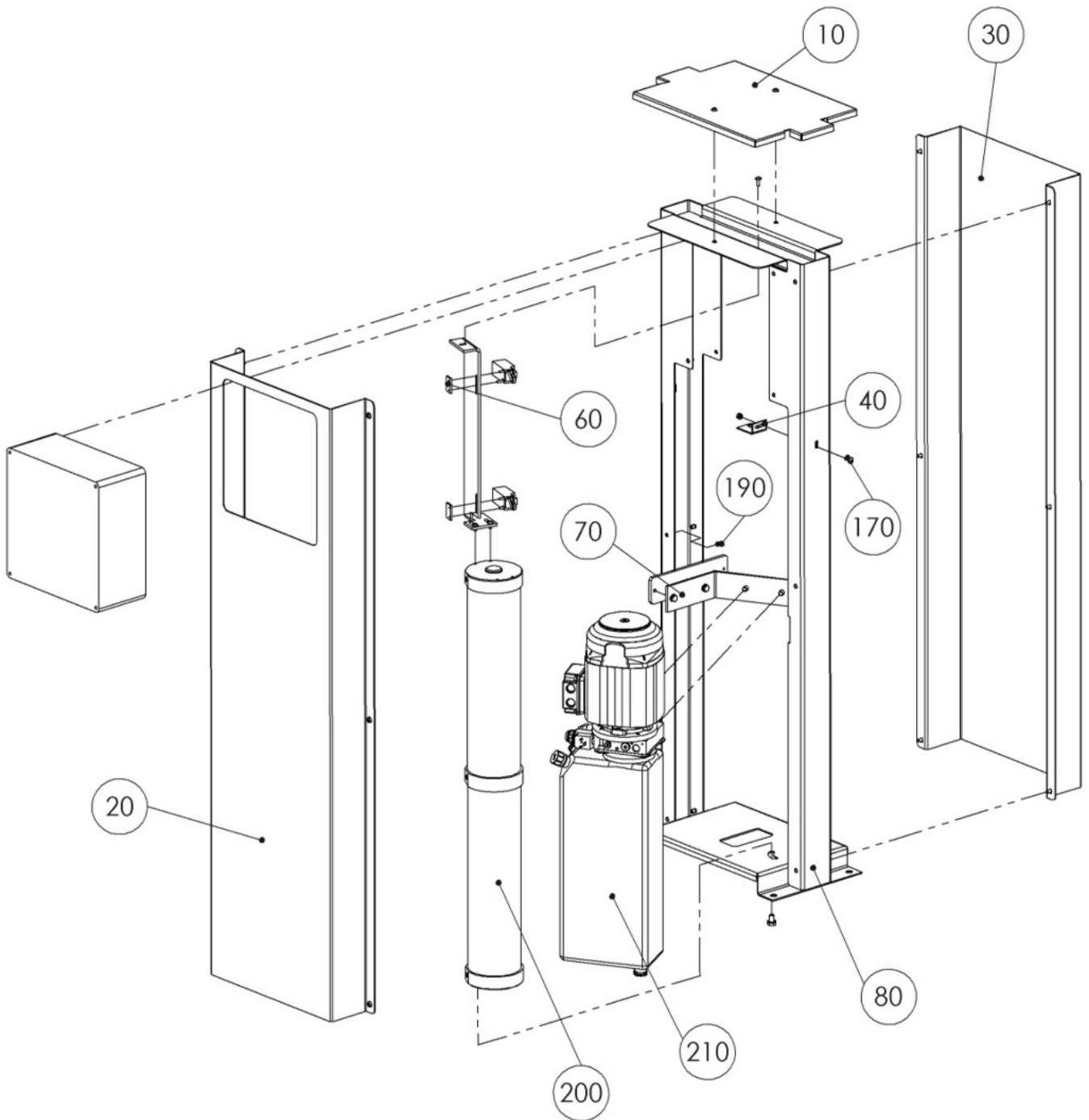

Item No.	Spare Part	Description	Tooltip	Article Number
10	Cover			020081 00054 0
20	Cover			020081 00055 0
30	Back Wall			020081 00056 0
40	Holder			020081 00059 0
50	Angle Plate			020081 00081 0
60	Mounting Bracket			020081 00082 0
70	Angle			020081 00097 0
80	Power Unit Cabinet			030081 00021 0
170	Binding Head Screw	M6x16		23 3080
190	Blind Rivet Nut	M6		23 2116
200	Flow Regulator			26000087
210	Hydraulic Power Unit		Section 1.5	26000088
220	Screw Plug	with Rubber Seal		27000013
230	Screw Plug	R 1/4"		27 4751
240	Sealing Washer	14x18x1,5		22 7603 141801

1.5 Hydraulic Power Unit

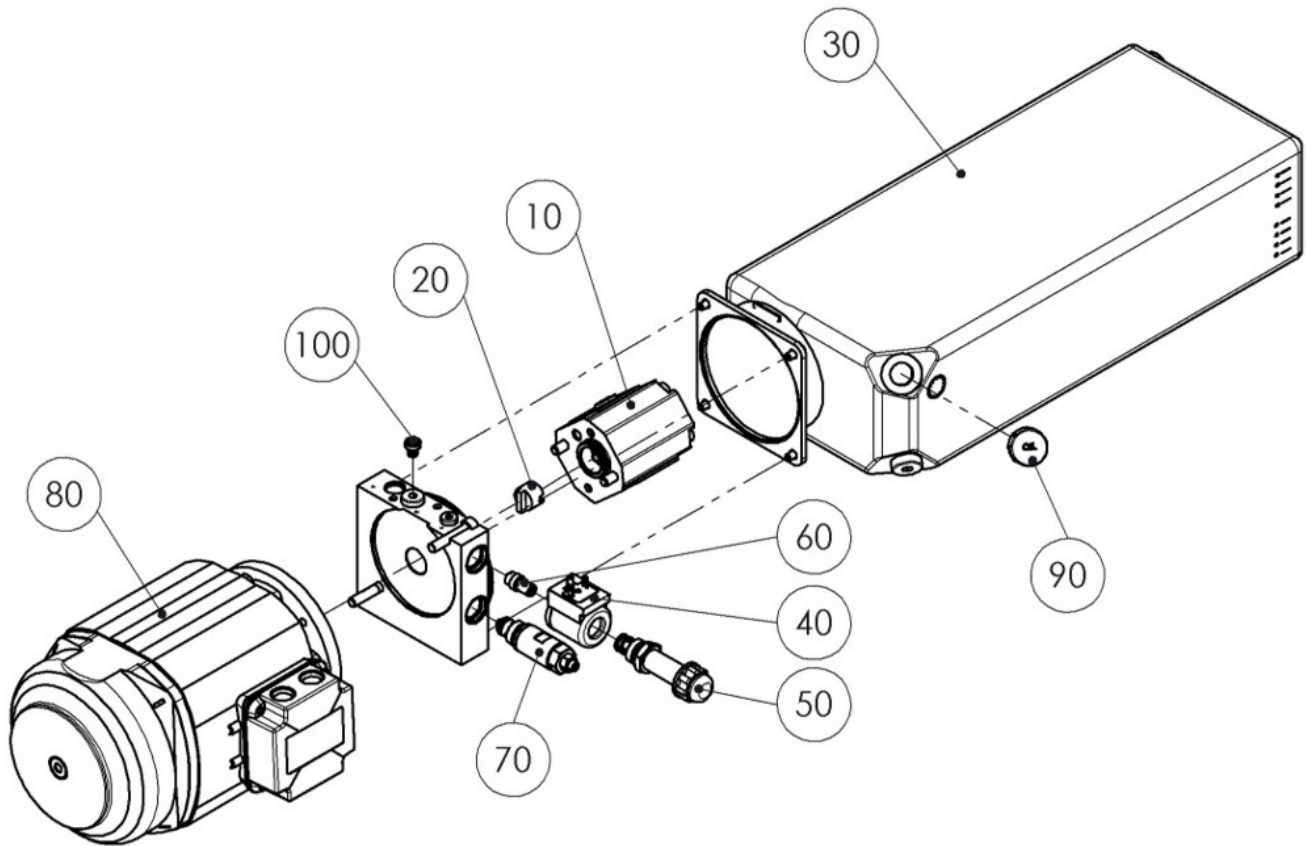

Item No.	Spare Part	Description	Article Number
10	Gear Pump	2,65ccm	26000035
20	Coupler		26000044
30	Oil Tank		26000069
40	Solenoid Coil	230VAC	26000107
50	2/2 Directional Control Valve		26000123
60	Flow Control Valve		26000137
70	Pressure Control Valve		26000153
80	Electric Motor	2,2kW;230/400V;50Hz	26000268
90	Air Filter	G1/2	26000326
100	Non-Return Valve		26000330







2 Small Parts

Item No.	Thumbnail	Spare Part	Description	Article Number
10		Rubber Block	100x150x20mm	17000007
20		Plastic Support	47x132x340mm	31 6900
30		Hard Rubber Block	50x115x95mm	31 6930
40		HP Hose	320mm	27 0621 032
50		HP Hose	450mm	27 0621 045
60		HP Hose	1000mm	27 0621 100
70		HP Hose	3300mm	27 0621 330
80		HP Hose	3500mm	27 0621 350





Item No.	Thumbnail	Spare Part	Description	Article Number
90		HP Hose	5000mm	27 0621 500
100		HP Hose	5500mm	27 0621 550
110		Screw Plug	R 1/4"	27 4751
120		T-Fitting	EVL 8 L	27 6430
130		T-Fitting	EVT 8 L	27 6433
140		Threaded Elbow Joint	EVW 8 L	27 6435
150		Straight Fitting	G 8 L	27 6437
160		Straight Fitting	GE 8 LR 1/4"	27 6461

Item No.	Thumbnail	Spare Part	Description	Article Number
170		Antiskid Coating	Black	35 1218
180		Antiskid Coating	Gray	35 1218 1
190		Hardener	Mixing Ratio 1:8	35 1219

3 Labels

Item No.	Thumbnail	Spare Part	Description	Article Number
10		Label	Maintenance	54 1376
20		Label	No Passengers Allowed	54 1398
30		Label	3000kg	54 1434
40		Label	Hydraulic Fluid	54 1436
50		Label	Safety Regulations	54 1494
60		Label	Main Switch	54 2132

4 Electrical Equipment

Item No.	Thumbnail	Spare Part	Description	Article Number
10		Suppressor	K-Serie 24V	50 0040
20		Changeover Relay	24 V AC/DC	50 0083
30		Main Contactor	4,0kW 24VDC	50 0194
40		Main Switch	4-pin 25A	50 1002
50		Installation Summer	22,5mm 230VAC	51 0287
60		Limit Switch		51 0317
70		Double Pushbutton		51 0511

Item No.	Thumbnail	Spare Part	Description	Article Number
80		Incandescent Lamp	LED white 24V	51 0542
90		Contact Element	NO Contact 3-4	51 0555
100		Contact Element	NC Contact 1-2	51 0556
110		Mounting Adapter	Front	51 0561
120		Protective Conductor	4,0mm 700mm lg. Ge/gn	51 4306
130		Tension Spring Clip	ST 4	51 5020
140		Tension Spring Clip	ST 4-PE	51 5027
150		Clamp	10/SI 5x20	51 5050

Item No.	Thumbnail	Spare Part	Description	Article Number
160		End Cover	D-ST 4	51 5064
170		Bridge	2-pin ST4	51 5077
180		Solenoid Valve Connector	with Cable Type A	53 2165
190		Screwed Cable Joint	M16 4,5-10	53 2752
200		Screwed Cable Joint	M20x1,5 9-14	53 2755
210		Screwed Cable Joint	M25 2x8mm	53 2791
220		Screwed Cable Joint	M25 3x6mm	53 2792
230		Limit Holder	TS 35	53 3047

Item No.	Thumbnail	Spare Part	Description	Article Number
240		Fuse	T 1,6 A	53 3064
250		Plastic Casing	Typ: FPC 30/30/13 7035	53 4158
260		Power Pack	24VDC/12VAC	56 0001
270		Control Element	24V 6A	58 0819

5 Anchors

* **NOTICE:** 23000256 to be used only with compensating plates!

TWIN	X	X																			
TRUCKLIFT										X	X										
SOLO III 2.5 M		X																			
SERVICELIFT	X																				
HL III 4.0 / 5.0										X	X										
HL 4.0									X	X											
HL 10000					X	X	X	X													
HL 9000 A					X	X	X	X													
BELTLIFT												X	X	X							
ECONLIFT					X	X	X	X													
ECON III 5.0										X	X										
ECON III 4.0										X	X									X	
ECON III 3.5												X	X	X	X	X	X				
ECON III 3.0												X	X	X	X	X	X				
ECON II												X	X	X	X	X	X				
DUO / MSL	X																				
CARLIFT			X																		
Article number (Unit: 1 Piece)	23 5050	23 5120	23 5165	23 6016	23 6017	23 6018 001	23 6019	23 6080	23 6090	23000240	23000241	23000242	23000255	23000256 *							
	Heavy Duty Anchor M10x150mm	Anchor Bolt M10x124mm	Express Anchor M10x165mm	Mortar Capsule M16	Anchor Bolt M16x165mm	Anchor Bolt M16x190mm	Anchor Bolt M16x250mm	Anchor Capsule M20	Anchor Bolt M20x220mm	Anchor Bolt M20x230mm	Cartridge (150ml) and Mixer	Anchor Bolt M16x200mm	Anchor Bolt M16x250mm	Anchor Bolt M12x145mm							
	